

NU·VU® FOOD SERVICE SYSTEMS

For NU-VU® Models:

**PMA-5/12
& PMA-5/18**
Pizza Ovens

**OWNER'S
MANUAL**

Revised:
27 December 2006

MENOMINEE, MICHIGAN 49858
(906) 863-4401

PMA-5/12 & PMA-5/18

TABLE OF CONTENTS

ABOUT YOUR NU-VU® OVEN	1
WARRANTY	4
RECEIPT AND INSTALLATION.....	7
START-UP	10
OPERATING INSTRUCTIONS	11
MAINTENANCE AND CLEANING GUIDE.....	13
SERVICE AND REPLACEMENT GUIDE	15
REPLACEMENT PARTS.....	18
ELECTRICAL SCHEMATICS.....	20

ABOUT YOUR NU-VU® OVEN

NU-VU® as a product line has been in existence for over twenty-five years. Its units are in use throughout the United States and Canada and have been exported to other parts of the world. NU-VU® continually modifies and updates its equipment to improve the capabilities as new innovations become available. This enables the user to obtain better and more useful results. NU-VU® currently manufactures an entire line of equipment in Menominee, Michigan.

Seminars for both dealers and customers are available either on-site in Menominee, Michigan; at the dealer's showroom; or on the customer's premises. Technical product information can be generated by customer requested testing of various products.

NU-VU® has, over a period of time, developed a series of Ovens, Proofers, Steamers, Smokers and Warmers designed to provide maximum performance with minimum energy requirements and care by the operator.

NU-VU® has combined quality construction, long life components, superior performance, multiple use operation, and amplified operating procedures to produce the finest equipment available. This means the end user has the best of ALL worlds.

NU-VU® equipment offers the widest range of options by the use of different air flow systems in conjunction with heat, moisture, steam and smoke.

NU-VU® AIR OVENS, PROOFERS AND WARMERS:

NU-VU® can provide a wide range of equipment with any of the following features:

- Bakery Ovens with either INTERNAL or EXTERNAL STEAM generating capabilities. These Ovens may be equipped with the NU-VU® COOK-N-HOLD option for broader use.
- COOK-N-HOLD Ovens for either high temperature or low temperature operation, with moisture and smoking capabilities.
- Low temperature Ovens with moisture and smoking capabilities.
- Steamer Ovens with high and low temperature capabilities.
- Multi-Ovens that dry bake, steam, and bake with steam.
- Bakery Proofer/Warmers with moisture and heat generating units with either manual fill or automatic humidity systems.
- General purpose Proofer/Warmers for reconstituting, slow cooking, holding and/or steaming.

NU-VU® MODELS PMA-5/12 AND PMA-5/18:

The Pizza Ovens of the NU-VU® PMA- series are electric and generally do not require ventilation hoods. However, the ultimate decision as to hood requirements rests with local authorities. NU-VU® has done operating cost comparisons with gas convection ovens. This data was generated in conjunction with input from Pacific Gas & Electric.

Based on standard assumptions as to operating conditions for each unit and costs supplied by Pacific Gas & Electric, the NU-VU® PMA-5/12 and PMA-5/18 Pizza Ovens are comparable in operating cost to like-sized pan table top gas convection ovens.

The PMA-5/12 and PMA-5/18 Pizza Ovens are specialty products from NU-VU®, and are designed specifically for the rapid baking of pizzas. The PMA-5/12 measures 26½" wide, 29" deep, and will hold a 12" pizza on each of its five baking decks. The PMA-5/18 measures 32 ⅝" wide, 36" deep, and will hold an 18" pizza on each of its five baking decks. Both units stand 34½" high from the base.

Each unit contains a single 550° solid-state Temperature Control to regulate the electric Heat Elements in the two interior Side Walls. Pizzas are baked on five separate Baking Decks that can be individually accessed through the partitioned glass Door on the front of the unit. An external compartment contains five digital-display Timer/Alarms to monitor the baking time for each Baking Deck; these Timers have a recall feature, which allows you to simply keep repeating the original set baking time.

Since the air flow is in a directional pattern the baking times are reduced over conventional deck and tray ovens. Actual baking times depend upon the Pizza recipe, baking temperature and environmental conditions.

The NU-VU® PMA-5/12 and PMA-5/18 Pizza Ovens are designed for the following:

- Easy product positioning
- Rapid, even baking
- Easy cleaning
- Simple operation
- Dependable components
- Low energy consumption
- Low maintenance
- Rapid servicing

AVAILABILITY AND TESTING:

A prospective customer may see a unit in operation as follows:

- At a dealer's showroom
- At an existing installation
- At the NU-VU® manufacturing facility

If contacted, NU-VU® will provide the information on the nearest location. In the event that a customer desires to test a unit at his place of business, arrangements can be made based on a specifically defined program. In the event that a customer wants to try a special product, arrangements can be made to determine what conditions are necessary for baking so the customer can determine the suitability for his program.

CONSTRUCTION:

The NU-VU® PMA-5/12 and PMA-5/18 Pizza Ovens are constructed of stainless steel both inside and outside. All of the frame members are welded to provide long life construction. Components such as temperature controls, timers, switches, motors, heating elements and others are thoroughly tested before shipment. On-going research and development projects are used to introduce the latest and most dependable parts.

SHIPMENT:

NU-VU® equipment is shipped directly from the factory or delivered from a dealer unless sold at a show or after a test or demonstration. Unless otherwise agreed to by NU-VU® freight is paid by the buyer F.O.B. from the NU-VU® manufacturing facility in Menominee, Michigan. Shipping time may vary depending upon the original shipping point, time of the year, and shipper or shippers used.

NU-VU® employs the latest accepted packaging standards to ensure that your equipment arrives in excellent condition. However, damage may still occur due to accident or negligent handling. For this reason it is necessary for the receiving party to immediately do a thorough inspection of the equipment when it arrives. NU-VU® works closely with all of its customers in tracing shipments to speed deliveries and minimize handling.

*** NOTICE ***

NATIONAL SANITATION FOUNDATION GUIDELINES REQUIRE THAT ALL INTERIOR PARTS BE REMOVABLE WITHOUT THE USE OF TOOLS. THIS EQUIPMENT HAS BEEN FACTORY ASSEMBLED TO SAFELY ACCOMMODATE ROUGH HANDLING THROUGH SHIPMENT AND ORIGINAL INSTALLATION. AFTER ANY MAINTENANCE, CLEANING OR REQUIRED SERVICE WORK THE INTERIOR SHEET-METAL PARTS SHOULD BE RE-ASSEMBLED AND FASTENED HAND-TIGHT ONLY, BUT STILL REMAIN TIGHT ENOUGH TO PREVENT THE MOVEMENT OR RATTLE OF PARTS.

NU-VU® EQUIPMENT WARRANTY

NU-VU® products are warranted against defects in workmanship and materials from the original date of shipment only. NU-VU® does not warrant against any damage that might occur during shipment or storage of the equipment. Any claim for such damage must be filed against the carrier or storage company. No other express warranty, written or oral, applies. No person is authorized to give any other warranty or assume any other liability on behalf of NU-VU®, except by written statement from an officer of NU-VU®.

Your NU-VU® equipment warranty is limited to the following time periods for the original owner only:

	<u>PARTS</u>	<u>LABOR</u>
Inside the United States	12 Months	12 Months
All areas outside the United States	12 Months	12 Months

These time limits will apply in all cases unless prior arrangements have been made and agreed to in writing.

The NU-VU® equipment warranty is composed of the following:

PARTS:

This limited warranty covers certain electrical, electronic and mechanical parts for the time periods shown above with the exception of those items detailed under Warranty Limitations. Customers who maintain an open account may purchase against their account. MasterCard, Visa and American Express credit cards are also accepted.

The return of defective parts is required. The return of a defective part or component must be made prior to the issuance of a credit on an open account. If a part that is returned tests satisfactory in the NU-VU® factory or at an authorized NU-VU® dealer or service agency, NU-VU® may withhold issuing credit. Replacement parts will be warranted for a period of *90 days* provided they are installed and used in a manner authorized by NU-VU®.

LABOR:

We require that you call our NU-VU® Service Department at (906) 863-4401 for service authorization BEFORE you call any service agency if you wish to claim a labor expense under this warranty. We may be able to solve your problem over the telephone, or we will schedule a warranty service call by a reliable service agency in your area.

This warranty covers the replacement and installation of parts and components which are included under **PARTS** for the time period listed above. This coverage is limited to the normal mileage allowance for a maximum travel radius of up to fifty (50) miles, and the normal labor rate times the allowable hours for performing the work as set forth in the following listing:

**NU-VU® FOOD SERVICE SYSTEMS
STANDARD TIME ALLOWANCES FOR WARRANTY REPLACEMENTS**

<u>Change performed</u>	<u>Change time</u>	<u>Test time</u>	<u>Total time</u>
Oven Motor/Rebalance Wheel	1 hr.	½ hr.	1½ hr.
Oven Heating Element	1 hr.	½ hr.	1½ hr.
Temperature Control	½ hr.	½ hr.	1 hr.
Temperature Sensor	½ hr.	½ hr.	1 hr.
Timers and/or Alarms	½ hr.	5 min.	½ hr.
Contactors/Relay	½ hr.	5 min.	½ hr.
Power Switch	¼ hr.	5 min.	¼ hr.
Indicator Light	¼ hr.	5 min.	¼ hr.

NU-VU® has determined that the listed times, which are based on the period necessary for a trained service person to perform the work noted, are fair and reasonable. If a problem is not diagnosed within a half hour, the service person must contact the NU-VU® Service Department via telephone at (906) 863-4401. Additional time for problem solving will not be allowed unless this procedure is followed. An appointment for servicing a unit should be set up since time will not be allowed for waiting to service a unit. Unless the service person justifies extra time for performing the work noted, charges for work performed by the service person in excess of the allowed time shall either be billed to the owner of the equipment or denied.



IMPORTANT: NU-VU® WILL NOT PAY FOR ANY SERVICE CALLS AS WARRANTY WORK IF A NU-VU® AUTHORIZED SERVICE AGENCY DETERMINES THAT YOUR UNIT IS SET UP AND OPERATING PROPERLY!

WARRANTY LIMITATIONS:

NU-VU® will pay for parts and labor under warranty if there is a defective component, but not for:

- Normal operational wear and tear on the following parts -
 - Light bulbs and fuses
 - Door gaskets, handles and catches
- Damage attributable to customer abuse, including -
 - Proofer water pan allowed to run dry and burn.
 - Proofer fan motor damaged from not following outlined Dry-Out Procedure.
 - Lack of regular cleaning or maintenance.
- Power supply problems, including -
 - Insufficient or incorrect voltage.
 - Damage to electrical components caused by a power surge or spike.
 - Incorrect installation (i.e., equipment not supplied with separate neutral or ground as required, or incorrect location of high-voltage power leg for 240-volt 3-phase units).
 - Damage to electrical components resulting from use of an incorrect power supply cord or circuit breaker.
- Operational problems resulting from customer's failure to follow established procedures outlined in the Owner's Manual.
- A service call if nothing is found to be wrong (any returned parts work as per spec when tested).

- Recalibration of temperature and humidity controls (all controls are carefully calibrated and tested at our facility before shipment).
- Any equipment moved from the place of original installation unless NU-VU® agrees in writing to continue the warranty after the relocation.
- Ongoing operational adjustments due to changing environmental conditions or normal wear and tear.
- Any overtime charges. NU-VU® will pay straight time only for any work performed on NU-VU® equipment.

Products must be installed and maintained in accordance with NU-VU® instructions. Users are responsible for the suitability of the products to their application. There is no warranty against damage resulting from accident, abuse, alteration, misapplication, inadequate storage prior to installation, or improper specification or other operating conditions beyond our immediate control. Claims against carrier damage in transit must be filed by the buyer; therefore, the buyer **must inspect** the product immediately upon receipt.

***THIS WARRANTY DOES NOT COVER ADJUSTMENTS
DUE TO NORMAL ON-GOING USE OF THE UNIT!!!***

PARTS RETURN PROCEDURE AND CONDITIONS:

The following procedure shall be followed for the return of parts to the factory for credit consideration:

- All parts received by NU-VU® must have a completed RETURN AUTHORIZATION FORM as supplied by NU-VU® with the replacement part.
- Package all return parts securely so that in-transit damage cannot occur.
- Prepay shipment. Any parts returned collect will be refused by our receiving department. Credit will be considered on proper returns only.
- As soon as parts are tested and confirmed to be defective credit will be issued against them.
- If the engineering test shows the component is not defective and is in good working condition it may be returned to you along with your request for payment.

RECEIPT AND INSTALLATION

RECEIPT:

It is essential to inspect the unit immediately when it arrives. NU-VU[®] has placed instructions on the packaging to help avoid damage in transit. However, negligent handling can produce hidden damage. These steps should be carefully followed:

- A. Inspect the entire perimeter of the package for damage or punctures to the packing material. This may indicate damage to the unit inside. Call any and all packing damage to the attention of the delivery person.
- B. If any packing damage is found, uncrate the unit immediately *in the presence of the delivery person* to determine if the unit is damaged. If any damage is found indicate the type and amount of damage on the shipping documents and notify NU-VU[®] at (906) 863-4401 immediately after filing a freight claim.
- C. Continue uncrating the unit carefully and check the entire unit (top, front, back and both sides) for any visible or hidden damage.
- D. Remove the unit from the shipping pallet and inspect the bottom for any damage.
- E. If any damage is noted after the driver leaves immediately contact the freight company and NU-VU[®] Food Service Systems.
- F. Check the Oven Door. Make sure the Door closes completely, and that the Door Gasket seals firmly (refer to the *DOOR TEST PROCEDURE* in the *SERVICE AND REPLACEMENT GUIDE*). If the Gasket does not seal correctly please contact the NU-VU[®] Service Department for instructions and assistance in any required adjustments.

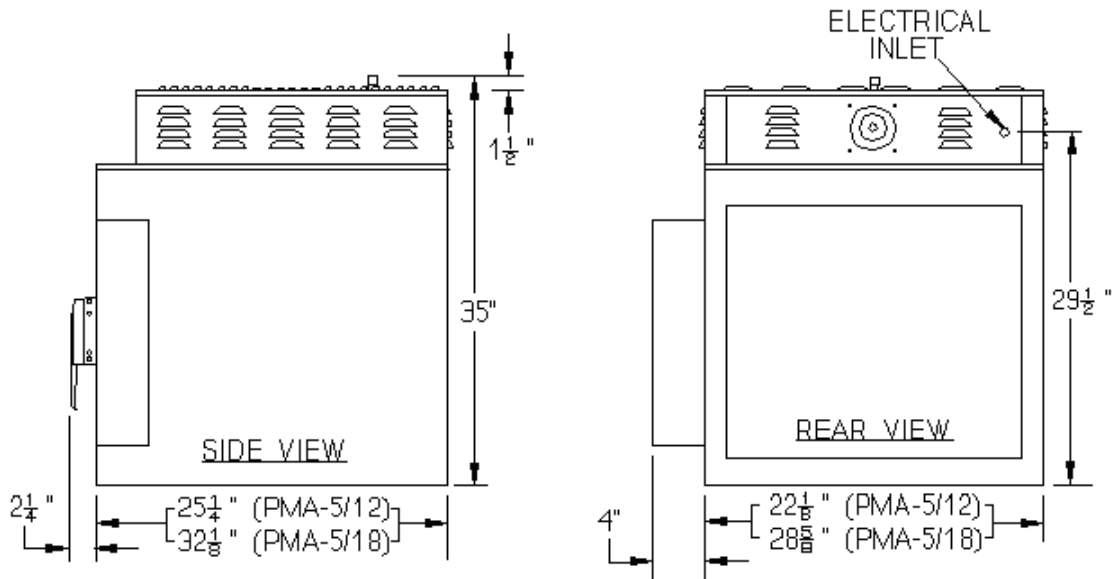

INITIAL START-UP PROCEDURE

- A. Make sure the INSTALLATION of the unit is complete and correct. Check the *exterior* of the unit. All cover panels must be in place (with the exception of the Outside Top), and the unit itself must be securely seated on a level surface.
- B. Check the *interior* of the unit. All interior parts must be installed and securely fastened. Make sure the Door is fully closed and latched (the Oven Motor will not run if the main Door is not fully closed). **YOU MUST REMOVE ALL PROTECTIVE TAPE PRIOR TO TURNING POWER ON.**
- C. Engage the main power supply and set the Power Switch to the **ON** position. The interior lights should come on and the Oven Blower Wheel should begin to rotate in a counter-clockwise direction as viewed from the inside of the Oven.

NOTE: The Oven Motor will not run if the Oven Door is not fully closed!

- D. Set the Temperature Control to 300°. The Temperature Control Indicator Light will illuminate and the Oven will begin to heat up.
- E. Carefully remove the Outside Top and measure the amperage on the exposed power supply lines. Compare these readings to the label on the side of your unit. If the readings and label differ by any great amount turn the unit **OFF** and call the NU-VU® Service Department immediately at (906) 863-4401. Carefully reposition the Outside Top on the Oven and press it into place if the amp readings and label coincide. Be careful not to pull or pinch any wires while replacing the Outside Top.
- F. Set each of the Timers in turn from 15 to 30 seconds and allow them to count down (refer to the *TIMER INSTRUCTIONS* in the *OPERATING GUIDE*). An electronic Alarm should sound at the end of each timed cycle. If a Timer or Alarm does not work please review the *TIMER INSTRUCTIONS* or refer to the *TROUBLE-SHOOTING GUIDE*. If you still have a problem call NU-VU® at (906) 863-4401 and ask for our Service Department. Someone there will be glad to assist you in any way possible.

NOTE. Press the Start-Stop key on the Timer to silence the Alarm earlier.

- G. Place an accurate and reliable oven thermometer in the center of the Oven and allow the Oven to heat to 300°. Compare the thermometer reading and the Temperature Control setting when the Temperature Control Indicator Light goes out. If they differ by less than 10° the Oven is ready for use. If there is a difference of 10° or more you may wish to adjust the Temperature Control.

Please call the NU-VU® Service Department at (906) 863-4401 before attempting to adjust the Temperature Control!!!

***Your PMA-5/12 or PMA-5/18 should now be
ready for all standard operations!!!***

OPERATING INSTRUCTIONS

The NU-VU[®] PMA-5/12 and PMA-5/18 Pizza Ovens are 5-Deck Ovens ideally suited for the rapid and continuous production of 12" to 18" pizzas. Each is simple and easy to install while the front-view glass Door and basic controls make it just as easy to operate. The unique partitioned Door allows the loading and unloading of each Baking Deck independently of the others, without opening the entire front of the unit, thereby reducing temperature fluctuations and eliminating lengthy recovery times.

These simple basic procedures should guide you through the operating process. If you have any questions, problems or comments please call NU-VU[®] toll-free at (906) 863-4401 and ask for the Service Department. Someone there will be glad to assist you.

- A. Make sure the Oven has been cleaned, and that all interior parts that may have been removed are installed correctly and fastened securely. Close the Oven Door securely and make sure all the Door Partitions operate freely and open fully.
- B. Set the Power Switch to the **ON** position. The interior lights will come on and the Motor Blower Wheel will rotate in a counter-clockwise direction (as viewed from inside the Oven).
- C. Set the Temperature Control to the desired operating temperature (usually 450° to 500°F for pizzas) and allow the Oven to heat up. Your Oven is ready for use when the Temperature Control Indicator Light goes out. The Oven should reach its operating temperature in approximately 15-18 minutes; you can use this time to prepare your product.
- D. Enter the baking time into the digital Timer for each Baking Deck (refer to the *TIMER INSTRUCTIONS*).
- E. Push in and lock down the small Door Lever for the Deck you wish to load.
- F. Use a pizza paddle to load your product on that Deck. Release the Door Lever; the Door Partition will swing back up to close the Deck opening.
- G. Start the Timer.
- H. Check your product when the Timer Alarm sounds. Unload your finished product by reversing the procedures in steps "E" and "F".
- I. Adjust the temperature and time settings if necessary and reload the Oven with more product.
- J. When you have finished using your PMA-5/12 or PMA-5/18 for the day set the Power Switch to the **OFF** position and complete the procedures outlined under *MAINTENANCE AND CLEANING*.

TIMER INSTRUCTIONS:

- A. The Power Switch must be in the **ON** position with the LEDs in the Timer Display Window showing **000**.
- B. Press either the UP or DOWN Time Set key to enter the desired time in minutes and seconds. The set time will appear in the Timer's Display Window.
- C. Start the Timer by pressing the Start-Stop key once. The Timer will count down one second at a time, flashing the remaining time in the Display Window. Pressing the Start-Stop key a second time will halt the Timer; the remaining time will flash in the Display Window. Pressing the Start-Stop key again will restart the Timer.
- D. When the set time expires the Display Window will flash **000** and the Timer Alarm will sound; the operator can silence the Alarm by pressing the Start-Stop key. After the Alarm is turned OFF the Timer will automatically reset itself to the last entered time. Pressing the Start-Stop key will restart the Timer.

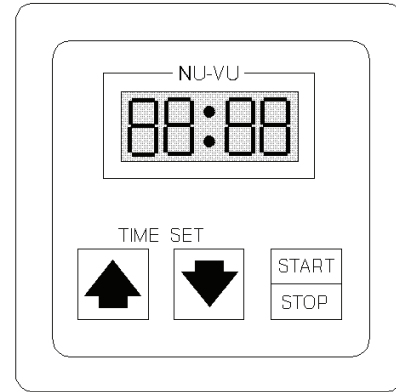

OPERATIONAL NOTES:

- The entered time changes by 1 second with each "click" of a Time Set key. Holding either key down changes the time by *1-second* increments for the first 35 seconds of change, *10-second* increments for the next 8 minutes of change, and *1-minute* increments for the remainder of the change to a maximum set time of 99 minutes and 00 seconds (**99:00** in the Display Window). Releasing the Time Set key restores the 1-second increment of change.
- The time setting can only be edited when the Timer is not running.
- A Timer can be reset at any time during the cooking cycle by holding the Start-Stop key for 5 seconds; Timer to its original set time. The set time can now be edited, or the Timer can be restarted to count down from this point.
- This digital Timer contains a short-term memory chip to prevent the loss of a Timer setting because of an accidental shut-down of the unit. The Timer will recall the last entered setting when the unit is restarted.

MAINTENANCE AND CLEANING GUIDE

MAINTENANCE:

NU-VU[®] equipment is designed to last for years of useful service. Careful consideration is given in selecting components for durability, performance and ease of maintenance. For example, the Oven Motor has sealed bearings and never needs to be lubricated. While NU-VU[®] equipment is designed for minimum care and maintenance certain steps are required by the user for maximum life and effectiveness:

- Proper installation of the equipment.
- Correct application and usage of the equipment.
- Dry-out Procedures performed daily.
- Thorough cleaning on a regular basis.

OVEN DRY-OUT PROCEDURE:

- A. Wipe up any standing moisture or liquid, both inside and outside of the Oven.
- B. Set the Temperature Control and Power Switch to **OFF**.
- C. Leave the Oven Door open about 6" to 8". The residual baking heat will dry out any moisture that may be trapped in the insulation or other components of the Oven.
- D. Leave the Oven Door slightly open while the Oven is not in use.

NOTE: After a day of baking especially heavy or wet products you may find it helpful to run your Oven at 200° for about 45 minutes to help dry out any excess moisture.



IMPORTANT: THESE DRY-OUT PROCEDURES MUST BE CARRIED OUT DAILY TO HELP MAINTAIN YOUR EQUIPMENT IN THE BEST POSSIBLE CONDITION. THE REMOVAL OF ALL RESIDUAL MOISTURE IN THE EQUIPMENT RETARDS ANY CORROSION OR DETERIORATION OF THE INSULATION AND ELECTRICAL COMPONENTS AND EXTENDS THE USEFUL SERVICE LIFE OF YOUR NU-VU[®] EQUIPMENT!!!

CLEANING:

Your PMA-5/12 or PMA-5/18 should be cleaned at least daily and as soon as possible after a spill has occurred. It is essential to maintain a clean unit, especially if the public views the unit in your place of business. The following general guidelines should be used for cleaning:

OVEN INTERIOR - -

- The Oven Door glass may be cleaned with any good glass-cleaning formula. Be sure to wipe down the Door Frame, and to clean behind the Door Gasket on the inside of the Oven Door. The Door can be removed for cleaning heavy soiling by opening the Door until it is perpendicular to the face of the unit and then lifting the Door straight up off of the Hinge pins.
- Dried-on debris or heavy soiling can be removed with hot soapy water followed by a rinse with clean fresh water. Wipe the Door dry before replacing it on the front of the Oven.

CAUTION: Abrasive cleaners may scratch the glass!

- The Oven interior should be wiped out daily. Remove the Oven Element Cover once a month for inspection and cleaning:
 - 1) Remove the thumbscrews along the top edge and pull the Element Cover down.
 - 2) Pull the Element Cover out through the front of the Oven to remove it.
- Inspect the Oven ceiling, the Blower Wheel, the Sidewalls and the Element Cover for mineral deposits and soiling. Wipe these parts down with hot water and a mild soap, followed by a rinse with clean fresh water and a mild sanitizing agent. Wiping the interior dry will help to prevent water spotting. Water spotting and all other mineral deposits should be removed with any mild mineral removal agent as soon as they are noticeable.
- Replace the Oven Element Cover. Make sure that the Element Cover is pushed all the way back and up for a tight fit. Secure it in place with the thumbscrews.
- The Oven Sidewalls should be removed on an as-needed basis for interior cleaning and mineral removal. Replace them the same way as the Element Cover, tight to the sides and all the way back.

OVEN EXTERIOR - -

- All exterior glass may be cleaned with any good glass-cleaning formula.
- The exterior metal surfaces can be cleaned with any good stainless steel cleaner or polish, or with hot water and a mild soap followed by a thorough rinse with clean fresh water if it is very soiled.

CAUTION: Do not allow any liquids near the Control surfaces!

***** CAUTION *****

NU-VU[®] DOES NOT RECOMMEND the use of any strong commercial or caustic product on this equipment. DO NOT allow any type of caustic cleaner to come into contact with any aluminum parts (such as Door frames or Baking Decks), the silicon rubber Door Gaskets, or any of the sealant in the Oven seams and joints. These types of cleaning compounds may cause discoloration and degradation of these parts resulting in permanent damage. DO NOT use bleach or bleach compounds on any chromed parts; bleach may damage chrome plating.

NOTE:

NU-VU[®] has had very good results with a product called JIFFY CLEANER. For standard cleaning simply spray JIFFY on and wipe off. Heavily soiled areas may require a short period of soaking. This cleaner is available through NU-VU[®] (Part #51-0002) or through your local Rochester/Midland distributor or representative.

SERVICE AND REPLACEMENT GUIDE

Your PMA-5/12 or PMA-5/18 has been designed to be serviced quickly and easily. In fact, any individual who has average mechanical ability can do the work. Our Service Department is also available to you Monday through Friday from 7:00 a.m. to 5:00 p.m. (Central Standard Time) should you find yourself with a situation or problem other than what is outlined here. Our technicians are also available via pager from 7:00 a.m. to 10:00 p.m. during week-ends and holidays. Call NU-VU® at (906) 863-4401 and ask for our Service Department to order replacement parts, ask questions, or offer comments.

This *SERVICE AND REPLACEMENT GUIDE* has been prepared to cover most normal service problems. If this "trouble-shooting" information does not provide a solution for your particular problem we ask that you call us for direct assistance. Calling our Service Department before calling in a repair technician can usually save you both time and unnecessary expense. We want to do everything we can to minimize your "down-time".

You may need to remove an access panel for servicing. **DO NOT** allow any access panels to drop. When work on the component is finished replace the panel with care, making sure that all wires are properly placed and not pulled or pinched. If more than one component is being worked on try to remove only one component at a time.

TEMPERATURE CONTROL, How to Adjust:

- A. Place a reliable thermometer (or the thermocouple of a test instrument) on a pan in the center of the Oven. Turn the unit **ON** and set the Temperature Control [22] to its normal setting. Allow the equipment to reach a stable operating temperature.
- B. Compare the Temperature Control setting to the reading on the test instrument when the Temperature Control Indicator Light [23] goes out. If there is a difference of 25° or more you will most likely need to recalibrate the Temperature Control.

***ATTENTION:** Please call the NU-VU® Service Department for the correct procedures to recalibrate your Oven!!!*

- C. If the difference is more than 5° but less than 25° a simple dial adjustment may solve the problem:
 1. Remove the Knob of the Temperature Control by pulling it straight out from the face of the Control Panel.
 2. Hold the black Knob securely with the back of the clear plastic dial toward you. Use a Phillips screwdriver to loosen the two screws from 3/4 to 1 full turn, *but do not remove them!*
 3. To increase the temperature inside the Oven carefully rotate the index line on the clear dial *clockwise*. Each "click" of adjustment is equal to approximately 5° of temperature change in the Oven. To decrease the inside temperature rotate the clear dial *counter-clockwise*.
 4. Gently tighten the dial screws and install the Knob. Check the Control setting against the test instrument and repeat this procedure if necessary.
- D. If this procedure fails to bring the temperature reading within the desired specs the Temperature Control or Temperature Control Sensor [6] may need to be replaced.

DOOR LATCH, How to Adjust:

The Door Latch used on the PMA- series Pizza Ovens is preset at the factory during the original installation. However, should your Door Latch ever need adjustment:

- Determine if the Oven Door [51] is too loose or too tight. If it is too loose the Door Latch [53] must be adjusted OUT (or away from the unit). If it is too tight the Latch must be adjusted IN (or towards the unit).
- Loosen the two acorn nuts inside the Latch Cover [54] with a 3/8" wrench. Pull the Latch Cover straight out from the Oven Door to remove it and remove the acorn nuts.
- Open the Door and take careful notice of the adjustment plate position against the Latch body. Hold the adjustment plate against the Latch body with one hand while you loosen the mounting screws with the other hand. Back the screws out approximately three full turns.
- CAREFULLY move the Latch body IN or OUT under the adjustment plate one notch at a time. Make sure the Latch stays straight up and down and tighten the mounting screws. Test the Door for proper closing and sealing (refer to the *DOOR TEST PROCEDURE*).
- Repeat steps "C" and "D" if you are not satisfied with the Door adjustment. If the Door tests as satisfactory make sure the mounting screws are tightened securely.
- Install the acorn nuts on the ends of the top and bottom Door Latch screws. Turn the nuts on all the way until they just contact the back side of the Latch mounting bracket, then loosen them by 1½ to 2 full turns. Install the Latch Cover and tighten the acorn nuts lightly to hold the Latch Cover in place.

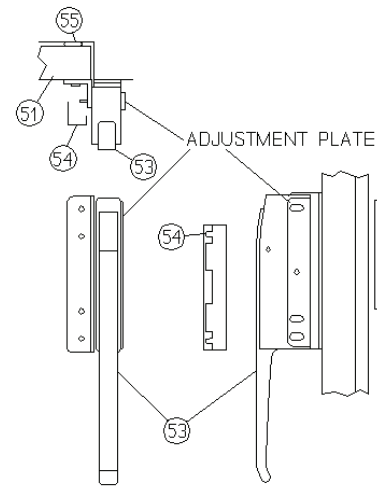

DOOR GASKET, How to Replace:

Follow these instructions to correctly install your Door Gasket with minimal problems. Use the installation kit provided. If you have any problems or questions call NU-VU® at (906) 863-4401. Ask for the Service Department.

- Remove all pieces of the old Gasket. Thoroughly clean the Door frame in the area of the new installation. Remove the old sealant and any baked-on deposits.



IMPORTANT: DO NOT DISASSEMBLE THE ACTUAL DOOR FRAME WHEN REPAIRING OR REPLACING THE DOOR GASKET!!!

- Pre-cut the replacement Gasket to a size slightly longer than you require.
- Put a small amount of soap water into and around the slot that the new Gasket will fit into (a small trigger spray bottle works well). This step is optional but will help in the installation.



- D. Position the new Gasket over the slot, allowing the ends to extend past the end of the slot. Press the mounting flange down into the slot on the Door frame. Use a roller tool to force the mounting flange into the slot by working the tool back and forth along the Gasket. Make sure the Gasket mounting flange is completely fitted into the slot and that the Gasket is free to slide back and forth in the slot.

IMPORTANT: DO NOT STRETCH OR PULL ON THE GASKET DURING THE INSTALLATION PROCESS. THIS WILL LATER CAUSE THE TRIMMED CORNERS TO SEPARATE AND PULL APART!!!

- E. Use a sharp knife or a single-edged razor blade to cut the ends of the Gasket at a 45° angle (you can use the mitered corner joint on the Door as an angle guide). Cut the Gasket about 1/4" longer than the required length and work the excess back into the slot. This extra Gasket will help to create a nice tight corner joint, and allows for any follow-up trimming that may be necessary.
- F. Work your way around the entire Door (or the section of the Door having the Gasket replaced). Make sure the Gasket is just tight into the corners. A bulging joint or pucker along the Gasket indicates a Gasket section that is cut too long. Joints that pull apart indicate a Gasket section (or sections) that are cut too short.



IMPORTANT: MAKE SURE THAT THE GASKET AND DOOR FRAME ARE COMPLETELY CLEAN AND DRY BEFORE APPLYING ANY SEALANT!!!

- G. Seal the corner joints after the entire Gasket is properly fitted. Pull the joints apart only enough to put sealant on all the *cut edges only*. Allow the Gasket joint to come together. Smooth out any excess sealant to form a smooth surface on the face of the Gasket. Add more sealant to any spots as necessary and smooth them down.
- H. A quality sealant will be dry to the touch and tack-free in one to two hours after application. However, it will not be completely cured until six to eight hours later. We recommend that you wait until after your sealant is completely cured before using your oven.



WARNING: SOME SEALANTS GIVE OFF ACIDIC FUMES AS THEY CURE. THESE FUMES MAY CAUSE IRRITATION TO THE EYES AND/OR NASAL PASSAGES. USE CAUTION WHEN OPENING YOUR UNIT AFTER WAITING FOR ANY FRESH SEALANT TO SET UP AND CURE!!!

REPLACEMENT PARTS LIST

(PMA-5/12 AND PMA-5/18)

Reference# Description Replacement Part #

ELECTRICAL COMPONENTS:

1	Power Terminal Block.....	50-1332
2	Ground Lug/Clamp.....	50-1329
3	Contactors 120V.....	50-0434
	Contactors 240V.....	66-2019
4	Heating Element, PMA-5/12:	
	208v, 2500w	60-0006-14-A
	240v, 2500w	60-0007-14-A
	Heating Element, PMA-5/18:	
	208v, 5000w	60-0146-1-C
	240v, 5000w	60-0151-1-A
5	Temperature Control Circuit Board.....	252-5001
6	Temperature Control Sensor	252-3001
7	Cooling Fan Assembly 120V	250-3001
	Cooling Fan Assembly 240V	888-5010
8	Oven Motor w/ Blower Wheel (PMA-5/12)	250-1002
	Oven Motor w/ Blower Wheel (PMA-5/18).....	250-1027
9	Thermal Overload Safety (Auto Reset)	66-1047
10	Door Micro Switch	252-2004
11	Light Fixture:	
	Socket, Globe, Gasket 120V	252-7004
	40-Watt Bulb 120V	50-0695
	Socket, Globe, Gasket 240V	888-0929
	40-Watt Bulb 240V	50-1025

CONTROLS:

12	Power Switch	252-6001
13	Temperature Control.....	252-5001
	Control Knob	253-2003
14	Temperature Control Indicator Light 120V.....	50-0029
	Temperature Control Indicator Light 240V.....	50-0030
15	Timer 99 Minute 120V	66-8133
	Timer 99 Minute 240V	66-9027
16	Timer Alarm.....	66-1113

INTERIOR COMPONENTS:

17 Baking Deck:
 PMA-5/12 200-2408-B
 PMA-5/18 151-9897
18 Paddle Stop 129-0227-C

DOOR COMPONENTS:

19 Door Assembly:
 PMA-5/12, Left Hinge 200-9873
 PMA-5/12, Right Hinge 200-9866
 PMA-5/18, Left Hinge 151-9931
 PMA-5/18, Right Hinge 151-9935
20 Door Hinge:
 Left Side 254-3011
 Right Side 254-3012
21 Latch/Catch Assembly 254-2007
22 Door Gasket 254-1001
23 Door Glass Panel:
 PMA-5/12, Left Hinge 200-9815
 PMA-5/12, Right Hinge 200-9818
 PMA-5/18, Left Hinge 151-9936
 PMA-5/18, Right Hinge 151-9933

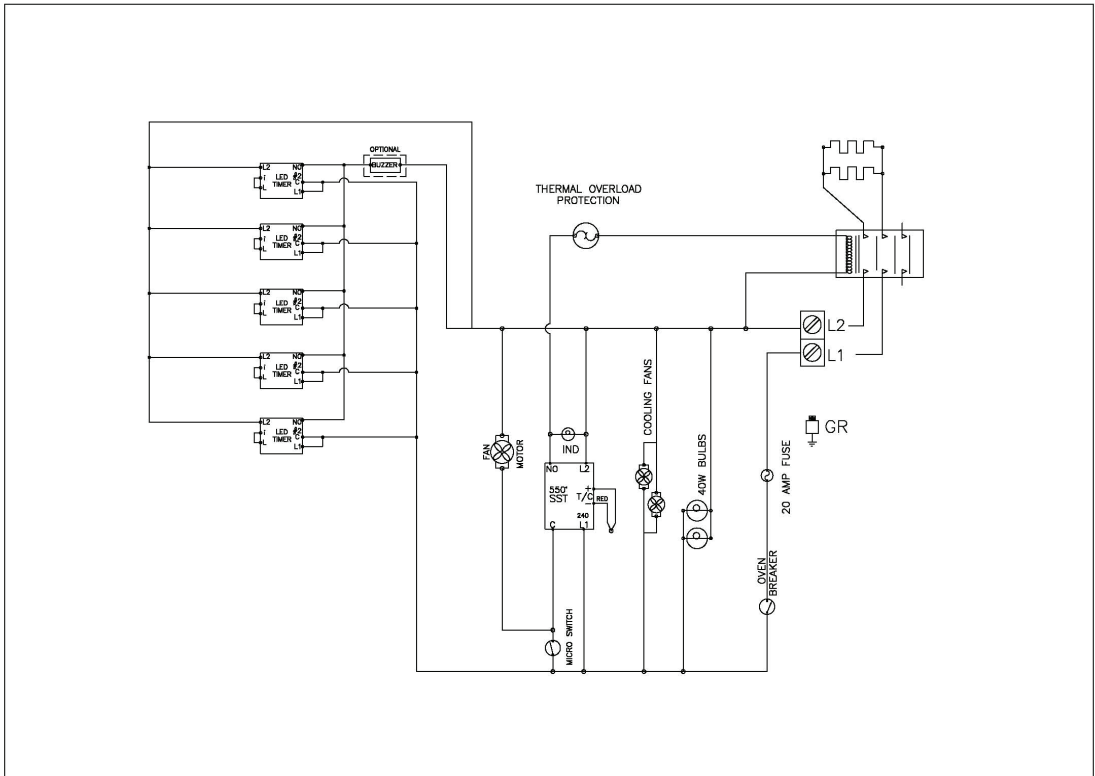

	NU-VU Food Service Systems 3600 13th STREET MENOMINEE, MICHIGAN 49858	REV: A	DESCRIPTION	CHANGED BY	DRAWN BY: CTC	VOLTAGE: 208/240	MODEL #: PMA-5/12, PMA-5/18	
				DATE	CHECKED:	PHASE: SINGLE	CUSTOMER	
					DATE: 12-21-06	WATTAGE:		
					BOM FILE #	CONTROLS: SOLID STATE	DWG. NO. 200-D0413	

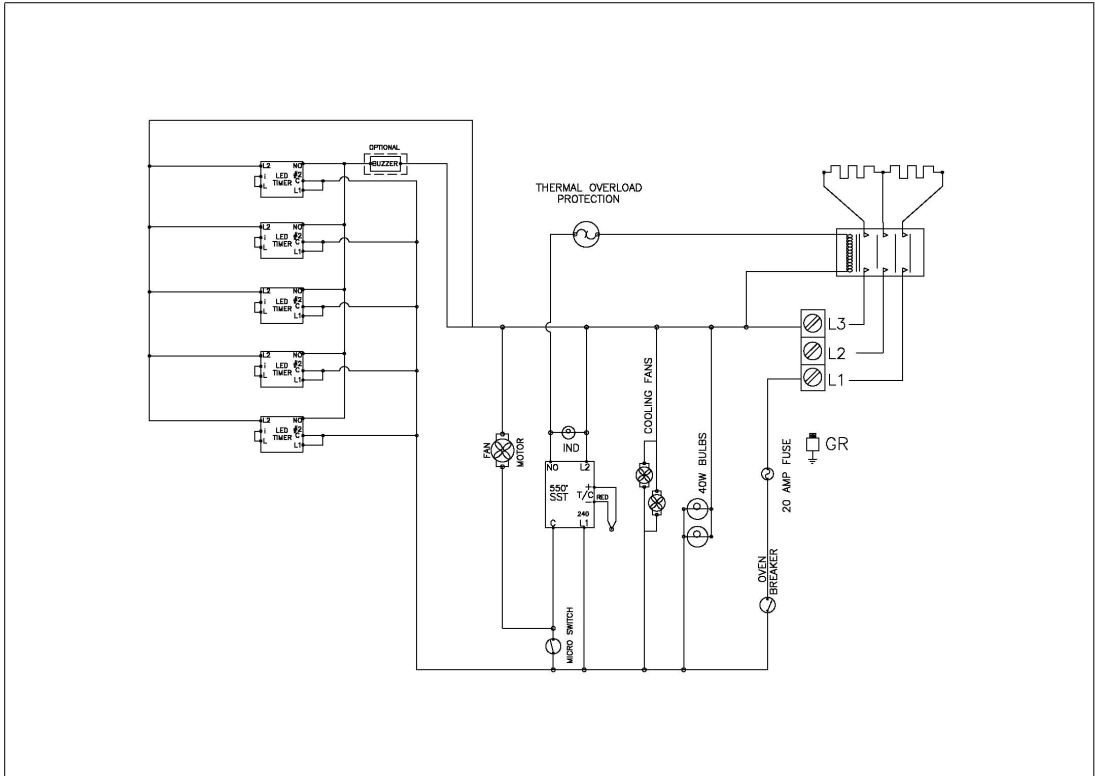

	NU-VU Food Service Systems 3600 13th STREET MENOMINEE, MICHIGAN 49858	REV: A	DESCRIPTION	CHANGED BY	DRAWN BY: CTC	VOLTAGE: 208/240	MODEL #: PMA-5/12, PMA-5/18	
				DATE	CHECKED:	PHASE: THREE	CUSTOMER	
					DATE: 12-21-06	WATTAGE:		
					BOM FILE #	CONTROLS: SOLID STATE	DWG. NO. 200-D0414	

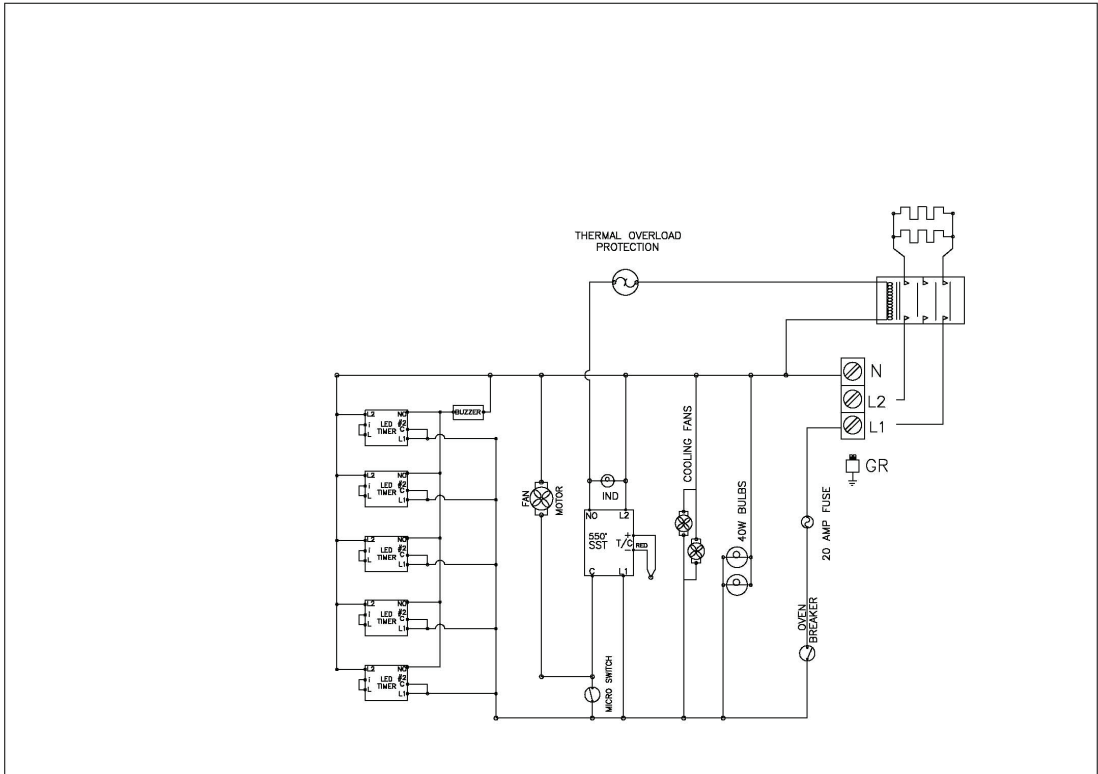

	NU-VU Food Service Systems 5600 13th STREET MENOMINEE, MICHIGAN 49858	REV: A	DESCRIPTION	CHANGED BY	DRAWN BY: CTC	VOLTAGE: 120/208-240	MODEL #: PMA-5/12, PMA-5/18
					CHECKED:	PHASE: SINGLE	CUSTOMER
			DATE	12-27-06	WATTAGE:	CONTROLS: SOLID STATE	DWG. NO. 200-D0415
			BOJ FILE #				

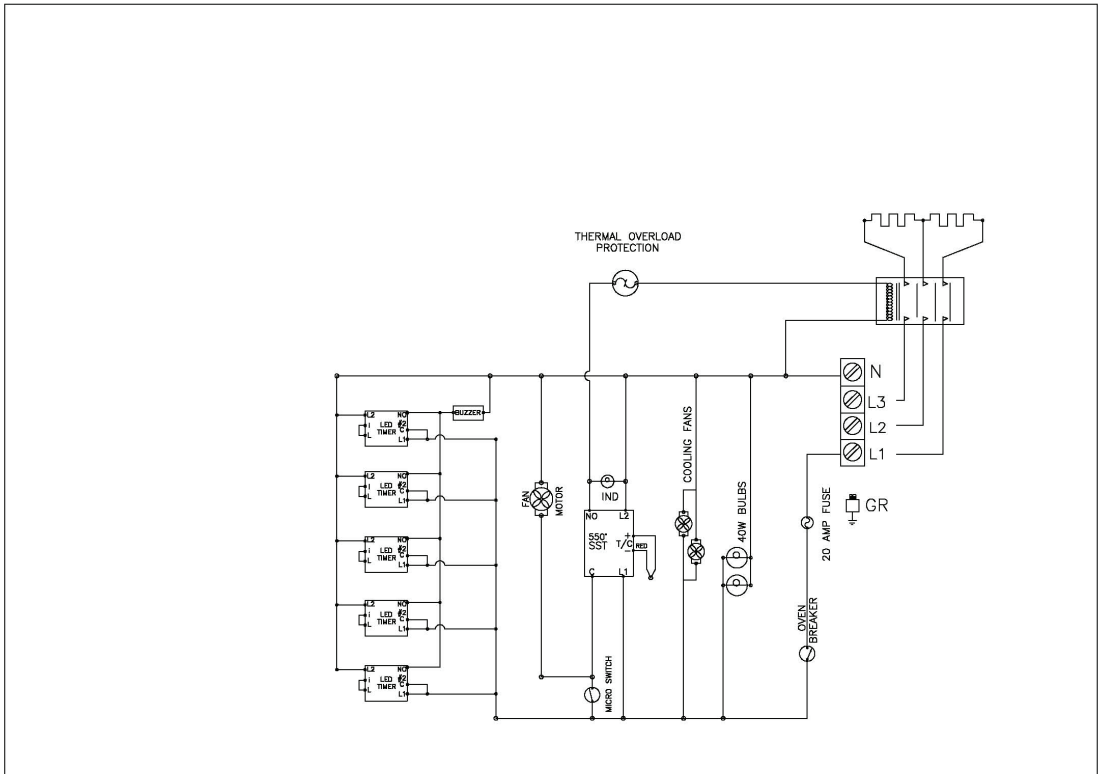

	NU-VU Food Service Systems 5600 13th STREET MENOMINEE, MICHIGAN 49858	REV: A	DESCRIPTION	CHANGED BY	DRAWN BY: CTC	VOLTAGE: 120/208-240	MODEL #: PMA-5/12, PMA-5/18
					CHECKED:	PHASE: THREE	CUSTOMER
			DATE	12-27-06	WATTAGE:	CONTROLS: SOLID STATE	DWG. NO. 200-D0416
			BOJ FILE #				